

EG3002

Electronic Engine Governor Controller User Manual



Engine Start Smoke Limiting function & IDLE Speed Setting
For External, Built-in, PT-Pump type and hydraulic drive actuators
Newly added "extreme slow response" engine setting

*

All manufacturer names and numbers are used for reference purpose only
and do not imply that any part is the product of these manufacturer.

SECTION 1 : SUMMARY

The EG3002 electronic controller takes a signal from a magnetic pickup (MPU) and compares it with a preset engine speed to control drive voltage to the actuator to maintain constant engine speed. The EG3002 has engine start smoke suppression, IDLE Speed control, Ramp Time setting, applicable for MPU frequency range of 600 to 9500 Hz. The unit has settings for use with Cummins high-gain (PT PUMP) engines and “extreme slow response” engines.

SECTION 2 : SPECIFICATION

Operating Voltage (Terminals 1, 2)

Voltage 10 – 32 Vdc

Speed Droop

0 – 4% (adjustable)

Outputs (Terminals 4, 5)

Voltage Max. 95% of Input Voltage
 Current Continuous 7A min. 0.5A
 Max. 15A 10 seconds

Stability

Speed variation less than +/- 0.25% at constant load

Static Power Consumption

Less than 1 Watt @ 12 Vdc
 Less than 2 Watt @ 24 Vdc

MPU Signal (Terminals 10, 11)

Frequency 10 – 10,000 Hz
 Voltage 1 – 120 Vac (RMS)

Speed Temperature Shift

Less than 3% at temperature range -40 to +80 °C

Frequency Adjustment

Speed Adjustment pot (25 turn)
 Setting range 600 – 9,500 Hz (With DIP Switch)

Environment

Operating Temperature -40 to+80 °C
 Storage Temperature -40 to +85 °C
 Relative Humidity Max. 95%
 Vibration 5.5Gs @ 60 Hz

Remote Speed Potentiometer (Terminals 6, 7, 9)

Max. +/- 7% @ 5 KΩ 1 watt potentiometer

Isochronous Load Sharing (ILS) (Terminals 6,8)

Input Resistance greater than 2 KΩ
 Input Ranges -5 Vdc to +5 Vdc / 0 to 10 Vdc
 Sensitivity 15%@10 Vdc

Dimensions

147.0 (L) x 114.0 (W) x 50.0 (H) mm
 5.79 (L) x 4.49 (W) x 1.97 (H) inch

Weight

690 g +/- 2%
 1.52 lb +/- 2%

IDLE Control (Terminals 2, 3)

Adjustment range 30 – 90% of Normal Speed

Ramp Time

3 – 20 seconds (adjustable)

SECTION 3 : APPEARANCE / DIMENSIONS / INSTALLATION DRAWING

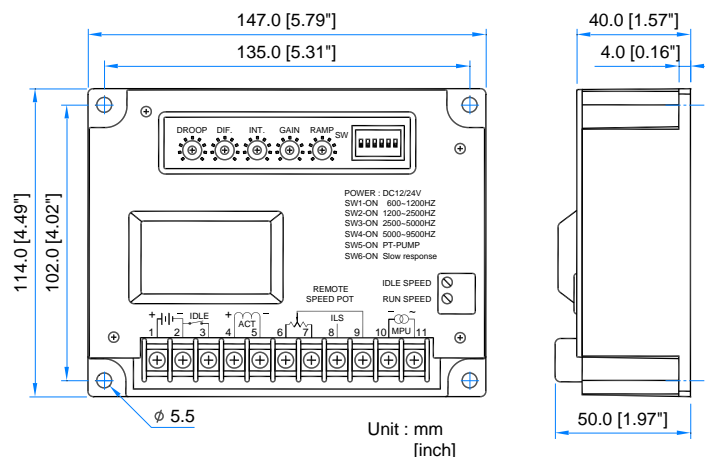

Figure 1 Outline Drawing

SECTION 4 : POTENTIOMETER ADJUSTMENTS AND DIP SWITCH FUNCTIONS

RAMP : Ramp Time
 Time for engine speed to climb from IDLE to operating speed. (3 to 20 seconds)

GAIN : Gain Setting

INT : Integral Setting

DIF : Differential Setting

DROOP : Speed Droop Setting

DIP Switch Functions

- SW 1 to 4 : Frequency Range Selection
- SW 5 ON : Cummins PT PUMP
- SW 6 ON : Extreme Slow Response engines

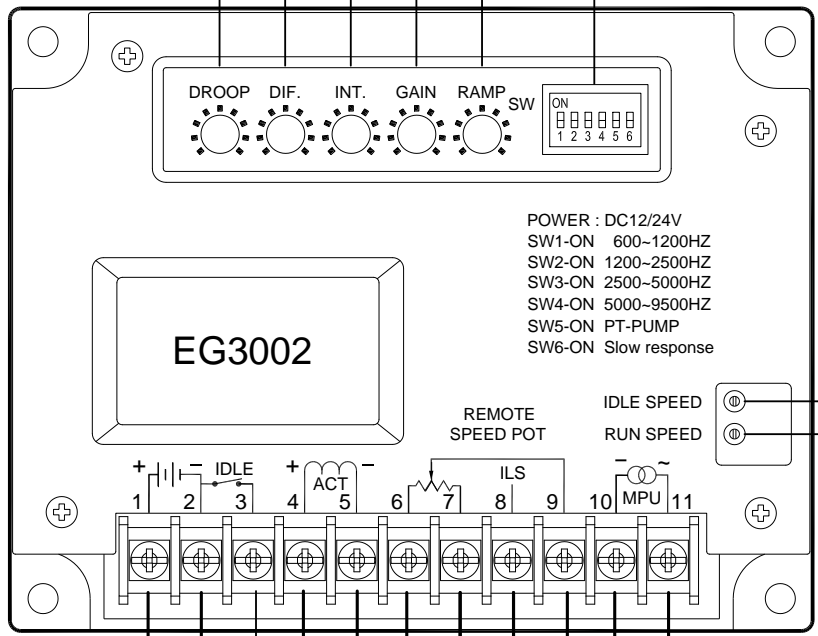

IDLE SPEED : IDLE Speed Setting
 When Terminals 2 & 3 shorted, use this pot to adjust IDLE speed.

RUN SPEED : Operating Speed Setting

1 · 2 : Battery Input
 Connect to genset battery. Use 14 AWG wire or larger

3 : IDLE Control Contact
 When shorted to terminal 2 unit will go to IDLE state.

4 · 5 : Output to Actuator
 Use 14 AWG wire or larger

10 · 11 : MPU Input
 Use shielded cable

6 · 7 · 9 : Remote Speed Potentiometer
 Connect a 5 KΩ potentiometer. Must use shielded cable.

6 · 8 : Isochronous Load Sharing (ILS) Input
 Analog input signal from the load sharing controller. Must be isolated from battery power. Terminal 6 is ground of load sharing controller. Terminal 8 is input signal from controller.

SECTION 5 : WIRING CONNECTIONS

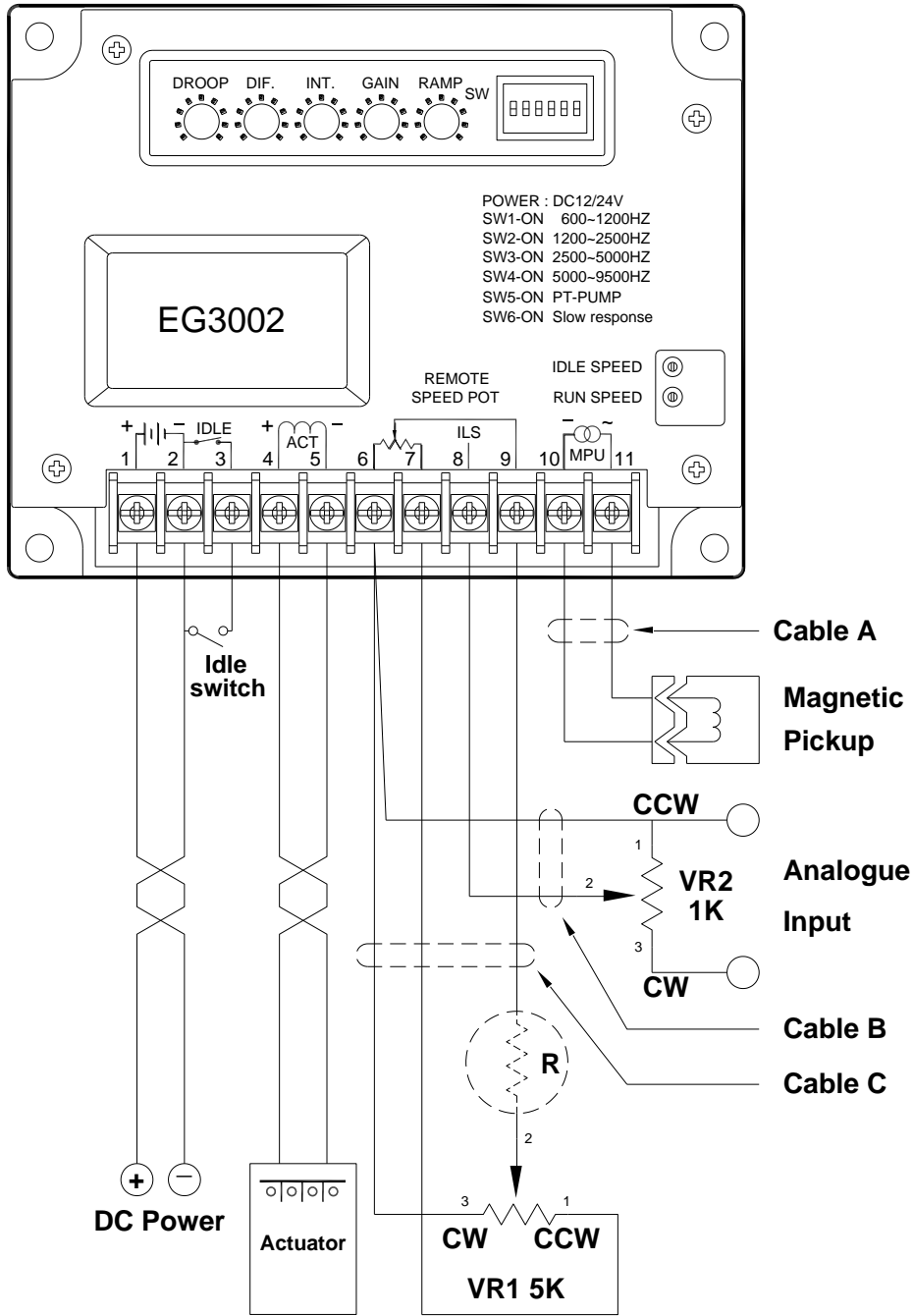

ATTENTION

1. The unit must be installed by qualified technical personnel. Improper installation, wiring or settings could lead to injury to personnel and/or damage to equipment.
2. This unit has no Over Speed Protection function. It is recommended to install a separate over speed protection device.
3. The battery connects directly to the controller with a fuse for protection. Use 20A slow-blow fuse.
4. Terminals 1, 2, 4, 5 must use 2.0 mm² (14 AWG) or larger wires.
5. Cables A, B, and C must be copper shielded cable of 26 AWG or larger.
6. In order to reduce noise interference copper shielding should be grounded on one end only.

SECTION 6 : ADJUSTMENT

6.1 Initial Settings Before Trial Run

6.1.1 With the engine OFF toggle the actuator linkage back and forth. The movement should be smooth with no gap in the linkage connection to the actuator. If there is a gap it will make it difficult to achieve stable settings.

6.1.2 Frequency Range Selection
Frequency range is selected according to the frequency of the signal sent by the magnetic pickup (MPU) at desired operating speed.

$$\text{MPU frequency} = \frac{\text{RPM} \times \text{Flywheel teeth}}{60 \text{ seconds}}$$

Frequency Range Selection	
SW-1 ON	600 – 1200 Hz
SW-2 ON	1200 – 2500 Hz
SW-3 ON	2500 – 5000 Hz
SW-4 ON	5000 – 9500 Hz

NOTICE

Only one DIP SW 1 – 4 can be turned ON.

If the number of flywheel teeth is not known then test each setting one by one from lowest (SW-2) to highest (SW-4).

6.1.3 Moving SW-5 to ON decreases the gain of the controller for use with Cummins PT-PUMP type or low-impedance, built-in actuators.

6.1.4 VR Settings

Run Speed : Turn counterclockwise to minimum.

IDLE Speed : Turn clockwise to maximum (If Cummins PT-PUMP type adjust counterclockwise to minimum).

Set all other values according to diagram below :

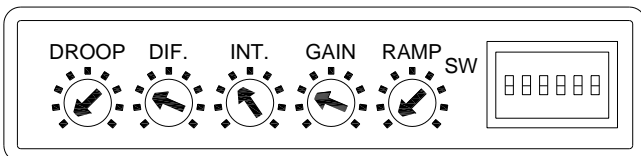

If an external VR is used then adjust to a middle position.

Open the IDLE switch between terminals 2 & 3.

NOTICE

RUN SPEED and IDLE SPEED VR are 25 turn precision potentiometers. When adjusted past its normal range it will make a clicking sound but will not be damaged.

6.2 Trial Run

6.2.1 Engine will not start
Refer to Section 7.1 Troubleshooting below for possible causes. If the engine still will not start normally then increase *Run Speed* setting or Frequency Range SW setting to a higher range (*Run Speed* should be set to minimum at this time)

6.2.2 If engine starts normally then slowly adjust *Run Speed* to the target speed. If unable to adjust to the target speed then set Frequency Range SW to next higher level. (*Run Speed* should be set to minimum at this time)

6.2.3 If the engine goes directly to over speed after starting then adjust the Frequency Range SW to the next lower level.

NOTICE

When conducting a trial run it is possible the engine speed cannot be controlled. Therefore, it is recommended to install an device to shutdown the engine, such as a fuel valve switch.

6.3 IDLE Speed and Ramp Time Settings

6.3.1 With the engine running at operating speed short Terminals 2 and 3. Engine speed will drop to IDLE speed at this time.

6.3.2 Adjust *IDLE Speed* counterclockwise to the desired IDLE level.

6.3.3 RAMP time too long it could cause the GCU to activate the under speed protection function. RAMP time too short could lead to incomplete combustion of fuel.

6.3.4 Open the connection between Terminals 2 & 3. Engine speed will climb from IDLE speed to operating speed. If RAMP time is inappropriate then short Terminals 2 & 3 again and adjust the *RAMP*. Repeat this step until setting is appropriate.

6.3.5 Stop the engine then start again. If the engine will not start then adjust the *IDLE Speed* clockwise to increase the IDLE setting.

6.4 Speed GAIN, INT, and DIF Setting

- 6.4.1 After the engine has started and reached operating speed adjust *GAIN* clockwise until engine speed oscillates rapidly. Then adjust *GAIN* counterclockwise to a point where engine speed just becomes stable. (Go to 6.4.3)
- 6.4.2 If engine speed is oscillating at a rate of once cycle every 2 to 5 seconds then slowly adjust *INT* counterclockwise until speed is stable. If adjustment to maximum does not stop the engine speed oscillation it could be an “extreme slow response” engine. Turn ON SW-6 (extreme slow response engine) and repeat this step again.
- 6.4.3 Observe the variation in engine speed between load and unload condition. If the rise or fall in speed is greater than allowed then adjust *DIF* clockwise. If engine speed becomes unstable after adjustment then return *DIF* to its original setting and increase *INT*. Repeat the steps above until linkage oscillates 3 to 5 times in one second and then becomes stable. This is the correct setting.

For details on speed gain (GAIN), integral (INT), derivative (DIF), refer to.

<http://edu.kutai.com.tw/egspeed.pdf>

NOTICE

1. If **GAIN** is set too low engine speed could accelerate directly to over speed when started or could oscillate slowly, with a period of 3 – 5 seconds, so should be avoided.
2. If **GAIN** and/or **DIF** are set too high engine speed could easily be made to oscillate. Adjust **GAIN** and **DIF** repeatedly until optimal settings are achieved.
3. Engine speed instability can be divided into slow oscillations (once every 2 to 5 seconds) and rapid oscillations (2 to 8 times per second); slow oscillation is usually because **GAIN** is too low and/or **INT** is too high. Rapid oscillations, however, can occur in two ways:
4. 2 – 4 times per second – **GAIN** setting too high.
4 – 8 times per second – **DIF** setting too high.

6.5 Remote Speed Pot Adjustment

The EG3002 provides two remote speed adjustment methods. One uses a 5 K Ω potentiometer to provide 5% speed adjustment remotely up to 60 meters. The other uses an analog input voltage that provides 1.5% speed adjustment for each 1 Vdc. For connection details see Section 5. Wiring Diagram.

NOTICE

Increasing or decreasing the resistance of the Remote Speed Pot will not affect frequency adjustment range.

To increase the external frequency adjustment range, short terminals 8 & 9 together and connect to the center tap of the remote speed pot.

To decrease the external frequency adjustment range install resistor (R) in series with terminal 9 and the center tap of remote speed pot.

6.6 Parallel Generator Operation

When a generator is used in parallel operation the speed DROOP is used to distribute power between generator sets. Clockwise adjustment will increase the rate of speed Droop. A speed Droop of 2% at maximum load is recommended.

DROOP setting calculation is as follows :

$$F_1 = (1 - D) \times F_2$$

F₁ = Droop speed with load (RPM or Hz)

D = Droop rate setting x load ratio

F₂ = Operating speed (RPM or Hz)

Example: If speed Droop is 3% under full load. When current load is 80% of generator capacity and engine speed is 1800 RPM then Engine speed will be (1 – 0.03 x 0.8) x 1800 = 1757 RPM.

SECTION 7 : TROUBLE SHOOTING

Fault Description	Possible Cause	Inspection (Fault Clearing) Actions
<p>7.1 Starter motor engaged but engine will not start</p>	<p>1. No electrical power</p> <p>2. MPU fault (failed, disconnected, installation incorrect)</p> <p>3. Actuator fault (failed, disconnected, etc.)</p> <p>4. Actuator defective</p> <p>5. Other causes</p>	<p>1. Confirm that Terminals 1 & 2 are connected to the genset battery, have normal voltage, and that polarity is correct.</p> <p>2. Disconnect wires from Terminals 10 & 11. Measure the resistance between the two wires. It must be between 10 – 1,000 Ω. If there is an open or short circuit then check whether the wiring between MPU and the controller is open or shorted.</p> <p>Directly measure the resistance of the MPU. It must be between 10 – 1,000 Ω. If there is a short circuit or an open then change the MPU.</p> <p>Measure the resistance between each pin of the MPU and its metal housing. There should be no conductance at all. If there is any conductance then replace the MPU.</p> <p>During engine start confirm that the input voltage to Terminals 10 & 11 is greater than 1 Vac. If less than 1 Vac check the gap between the tip of the MPU and the flywheel teeth. The distance should be 0.037 mm to 0.127 mm.</p> <p>3. If the two items above are both normal then check whether Terminals 4 & 5 have a voltage output during cranking. If there is an output but the actuator does not activate then check whether the wiring to the actuator is open or not.</p> <p>4. Disconnect the wires from the controller to the actuator. Confirm that the wiring is not shorted and also has no conductivity to the housing of the actuator.</p> <p>Connect actuator wires directly to the battery and confirm that the actuator operates through its full range.</p> <p>5. With the engine stopped, manually toggle the actuator linkage to see whether the action is smooth.</p> <p>If that item is normal then manually toggle the actuator linkage during engine cranking. If the engine still does not start then check whether engine fuel supply is normal (fuel level, fuel valve closed, stop solenoid linkage, etc.)</p>

Fault Description		Possible Cause	Inspection (Fault Clearing) Actions
7.2 Low engine speed		<ol style="list-style-type: none"> 1. Incorrect setting of Frequency Range SW 2. Engine remains in IDLE mode 3. Caused by remote speed signal input 4. Problem with MPU signal 	<ol style="list-style-type: none"> 1. Refer to the "Settings" section in this manual. 2. Check whether Terminals 2 & 3 are shorted. 3. If any of Terminals 6, 7, 8, or 9 are in use, then first disconnect all wires and test again. If engine speed returns to normal this means there is a problem with remote speed signal input. 4. Check whether MPU is disconnected (Must be directly connected to Terminals 10 & 11. Resistance of 10 – 1,000Ω is normal. Check that MPU has been connected with shielded wire grounded at one end. Repair wiring as required.
7.3 High engine speed		<ol style="list-style-type: none"> 1. Incorrect setting of Frequency Range SW 2. Caused by remote speed signal input 3. Problem with MPU signal 4. Controller defective 	<ol style="list-style-type: none"> 1. Refer to the "Settings" section in this manual. 2. If any of Terminals 6, 7, 8, or 9 are in use, then first disconnect all wires and test again. If engine speed returns to normal this means there is a problem with remote speed signal input. 3. Check whether MPU is disconnected (Must be directly connected to Terminals 10 & 11. Resistance of 10 – 1,000Ω is normal. Check that MPU has been connected with shielded wire grounded at one end. Repair wiring as required. 4. With engine OFF apply power to the controller, if actuator linkage moves or if there is a voltage output on Terminals 4 & 5 this indicates the controller is defective.
7.4 Engine speed will not stabilize (Steady oscillations)		<ol style="list-style-type: none"> 1. Incorrect adjustments or settings 2. Incorrect installation of actuator linkage 	<ol style="list-style-type: none"> 1. Refer to the "Settings" section in this manual. 2. Too much mechanical gain from actuator linkage. Adjust or change the linkage to reduce mechanical gain.
7.5 Engine speed will not stabilize (irregular oscillations)		<ol style="list-style-type: none"> 1. Problem with linkage 	<ol style="list-style-type: none"> 1. With the engine OFF toggle the actuator linkage back and forth. The movement should be smooth with no gap in the linkage connection to the actuator or rust causing resistance. If there is a gap it will make it difficult to achieve stable settings. MPU signal is picking up interference. It is recommended to use shielded cable with one end grounded, or shorten the wiring connecting the MPU.

- ※ Appearance and specifications of products are subject to change for improvement without prior notice.
- ※ NOTE : The shielded cable of the magnetic pick-up (MPU) cannot be spliced or it will allow electromagnetic interference to the controller.